

TOPICAL PAST PAPER QUESTIONS WORKSHEETS

AS & A Level Physics (9702) Paper 4

[Structured questions]

Exam Series: February/March 2016 - May/June 2024

Format Type B:

Each question is followed by its answer scheme



EXAMINENT.COM
Eminent Exam Preparation Resources

Introduction

Each Topical Past Paper Questions Workbook contains a comprehensive collection of hundreds of questions and corresponding answer schemes, presented in worksheet format. The questions are carefully arranged according to their respective chapters and topics, which align with the latest IGCSE or AS/A Level subject content. Here are the key features of these resources:

1. The workbook covers a wide range of topics, which are organized according to the latest syllabus content for Cambridge IGCSE or AS/A Level exams.
2. Each topic includes numerous questions, allowing students to practice and reinforce their understanding of key concepts and skills.
3. The questions are accompanied by detailed answer schemes, which provide clear explanations and guidance for students to improve their performance.
4. The workbook's format is user-friendly, with worksheets that are easy to read and navigate.
5. This workbook is an ideal resource for students who want to familiarize themselves with the types of questions that may appear in their exams and to develop their problem-solving and analytical skills.

Overall, Topical Past Paper Questions Workbooks are a valuable tool for students preparing for IGCSE or AS/A Level exams, providing them with the opportunity to practice and refine their knowledge and skills in a structured and comprehensive manner. To provide a clearer description of this book's specifications, here are some key details:

- Title: Cambridge AS & A Level Physics (9702) Paper 4 Topical Past Papers
- Subtitle: Exam Practice Worksheets With Answer Scheme
- Examination board: Cambridge Assessment International Education (CAIE)
- Subject code: 9702
- Years covered: February/March 2016 - May/June 2024
- Paper: 4
- Number of pages: 967
- Number of questions: 396

Contents

1	Motion in a circle	7
1.1	Centripetal acceleration	7
2	Gravitational fields	21
2.1	Gravitational force between point masses	21
2.2	Gravitational field of a point mass	49
2.3	Gravitational potential	78
3	Temperature	117
3.1	Temperature scales	117
3.2	Specific heat capacity and specific latent heat	120
4	Ideal gases	145
4.1	Equation of state	145
4.2	Kinetic theory of gases	149
5	Thermodynamics	181
5.1	Internal energy	181
5.2	The first law of thermodynamics	191
6	Oscillations	247
6.1	Simple harmonic oscillations	247
6.2	Energy in simple harmonic motion	276
6.3	Damped and forced oscillations, resonance	301
7	Electric fields	349
7.1	Uniform electric fields	349
7.2	Electric force between point charges	352
7.3	Electric field of a point charge	354
7.4	Electric potential	375
8	Capacitance	421
8.1	Capacitors and capacitance	421
8.2	Energy stored in a capacitor	442
8.3	Discharging a capacitor	458
9	Magnetic fields	487
9.1	Force on a current-carrying conductor	487
9.2	Force on a moving charge	497
9.3	Magnetic fields due to currents	549
9.4	Electromagnetic induction	560
10	Alternating currents	623
10.1	Characteristics of alternating currents	623
10.2	Rectification and smoothing	652

11 Quantum physics	679
11.1 Energy and momentum of a photon	679
11.2 Photoelectric effect	691
11.3 Wave-particle duality	723
11.4 Energy levels in atoms and line spectra	733
12 Nuclear physics	757
12.1 Mass defect and nuclear binding energy	757
12.2 Radioactive decay	792
13 Medical physics	857
13.1 Production and use of ultrasound	857
13.2 Production and use of X-rays	888
13.3 PET scanning	927
14 Astronomy and cosmology	937
14.1 Stellar radii	937
14.2 Hubble's law and the Big Bang theory	949

Chapter 1

Motion in a circle

1.1 Centripetal acceleration

1. 9702_s24_qp_42 Q: 1

(a) Define the radian.

.....
 [1]

(b) A circular metal disc spins horizontally about a vertical axis, as shown in Fig. 1.1.

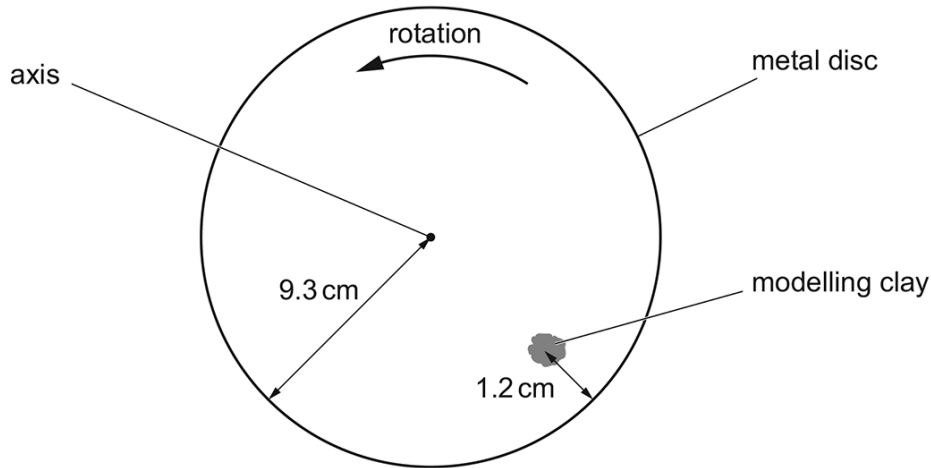

Fig. 1.1 (not to scale)

A piece of modelling clay is attached to the disc.

For the instant when the piece of modelling clay is in the position shown, draw on Fig. 1.1:

- (i) an arrow, labelled V , showing the direction of the velocity of the modelling clay [1]
 (ii) an arrow, labelled A , showing the direction of the acceleration of the modelling clay. [1]

(c) The metal disc in Fig. 1.1 has a radius of 9.3 cm.

The centre of gravity of the modelling clay is 1.2 cm from the rim of the disc and moves with a speed of 0.68 m s^{-1} .

(i) Calculate the angular speed ω of the disc.

$$\omega = \dots\dots\dots \text{ rads}^{-1} \text{ [2]}$$

(ii) Calculate the acceleration a of the centre of gravity of the modelling clay.

$a = \dots\dots\dots \text{ms}^{-2}$ [2]

(d) A second piece of modelling clay is attached to the disc in the position shown in Fig. 1.2.

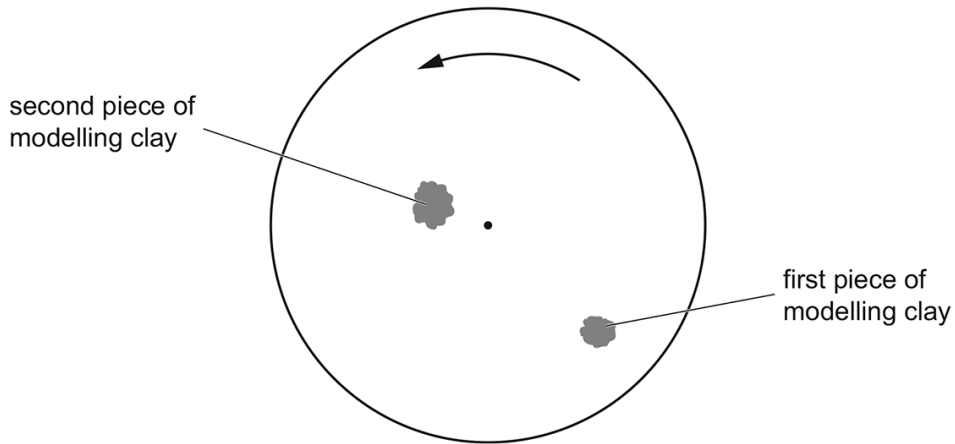

Fig. 1.2

The second piece of modelling clay has a larger mass than the first piece.

By placing **one** tick (✓) in each row, complete Table 1.1 to show how the quantities indicated compare for the two pieces of modelling clay.

Table 1.1

quantity	less for second piece than first piece	same for both pieces	greater for second piece than first piece
angular speed			
linear speed			
acceleration			

[3]

[Total: 10]

Answer:

Question	Answer	Marks
(a)	angle (subtended at the centre of a circle) when arc (length) = radius	B1
(b)(i)	arrow, labelled V, pointing in NE direction	B1
(b)(ii)	arrow, labelled A, pointing in NW direction	B1
(c)(i)	$v = r\omega$	C1
	$\omega = 0.68 / (0.093 - 0.012)$ $= 8.4 \text{ rad s}^{-1}$	A1
(c)(ii)	$a = v^2 / r$ or $a = r\omega^2$	C1
	$a = 0.68^2 / (0.093 - 0.012)$ or $(0.093 - 0.012) \times 8.4^2$ $= 5.7 \text{ m s}^{-2}$	A1
(d)	angular speed: same for both pieces	B1
	linear speed: less for second piece than first piece	B1
	acceleration: less for second piece than first piece	B1

_____ compiled by examinent.com _____

2. 9702_s23_qp_41 Q: 2

A steel sphere of mass 0.29 kg is suspended in equilibrium from a vertical spring. The centre of the sphere is 8.5 cm from the top of the spring, as shown in Fig. 2.1.

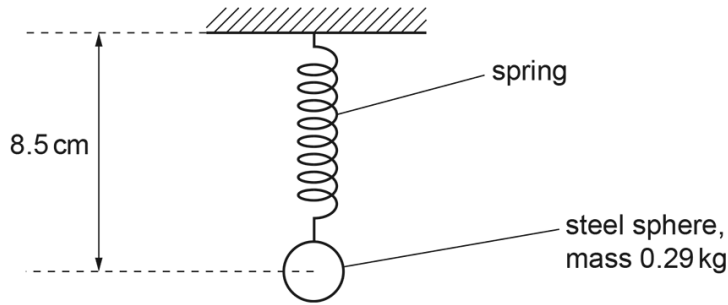

Fig. 2.1

The sphere is now set in motion so that it is moving in a horizontal circle at constant speed, as shown in Fig. 2.2.

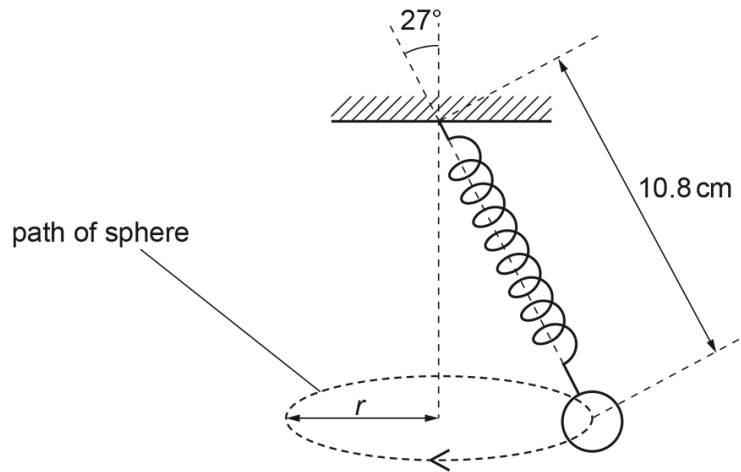

Fig. 2.2

The distance from the centre of the sphere to the top of the spring is now 10.8 cm.

(a) Explain, with reference to the forces acting on the sphere, why the length of the spring in Fig. 2.2 is greater than in Fig. 2.1.

.....

.....

.....

.....

.....

..... [3]

(b) The angle between the linear axis of the spring and the vertical is 27° .

(i) Show that the radius r of the circle is 4.9 cm.

[1]

(ii) Show that the tension in the spring is 3.2 N.

[2]

(iii) The spring obeys Hooke's law.

Calculate the spring constant, in N cm^{-1} , of the spring.

spring constant = N cm^{-1} [2]

(c) (i) Use the information in (b) to determine the centripetal acceleration of the sphere.

centripetal acceleration = m s^{-2} [2]

(ii) Calculate the period of the circular motion of the sphere.

period = s [2]

[Total: 12]

Answer:

Question	Answer	Marks
(a)	horizontal force on sphere causes centripetal acceleration	B1
	weight of sphere is (now) equal to vertical component of tension or horizontal and vertical components (of force) (now) combine to give greater tension (in spring)	B1
	greater tension in spring so greater extension of spring	B1
(b)(i)	$r = 10.8 \times \sin 27^\circ = 4.9 \text{ cm}$	A1
(b)(ii)	$T \cos \theta = mg$ or $T \cos \theta = W$ and $W = mg$	C1
	$T \cos 27^\circ = 0.29 \times 9.81$ leading to $T = 3.2 \text{ N}$	A1
(b)(iii)	$\Delta T = 3.2 - (0.29 \times 9.81)$	C1
	$k = \Delta T / \Delta x$ $= [3.2 - (0.29 \times 9.81)] / [10.8 - 8.5]$ $= 0.15 \text{ N cm}^{-1}$	A1
(c)(i)	centripetal acceleration $= (T \sin \theta) / m$ $= (3.2 \times \sin 27^\circ) / 0.29$	C1
	$= 5.0 \text{ m s}^{-2}$	A1
Question	Answer	Marks
(c)(ii)	$a = r\omega^2$ and $\omega = 2\pi / T$ or $a = v^2 / r$ and $v = 2\pi r / T$	C1
	$T = 2\pi \times \sqrt{(0.049 / 5.0)}$ $= 0.62 \text{ s}$	A1

compiled by examinent.com

3. 9702_w23_qp_42 Q: 1

(a) Define the radian.

.....
 [1]

(b) The minute hand of a clock revolves at constant angular speed around the face of the clock, completing one revolution every hour. A small piece of modelling clay is attached to the hand with its centre of gravity at a distance L from the fixed end of the hand, as shown in Fig. 1.1.

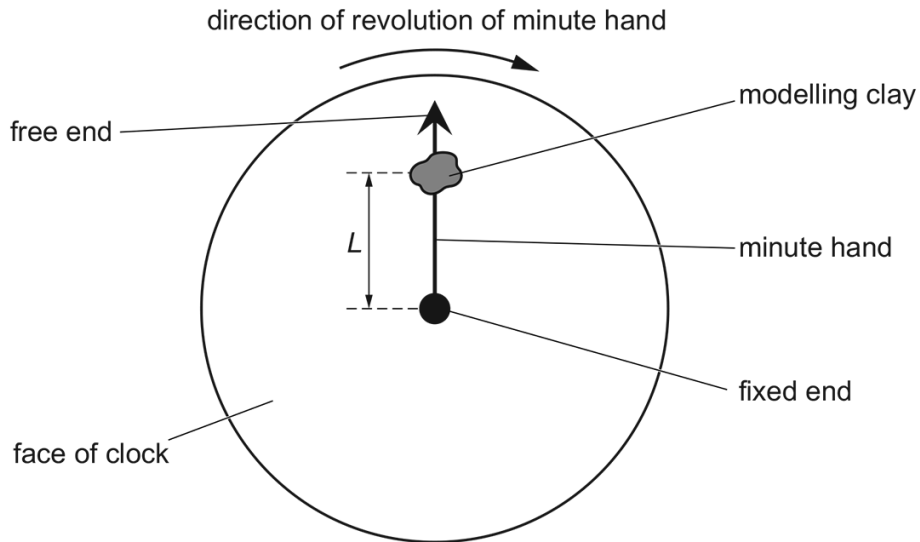

Fig. 1.1

Calculate the angular speed ω of the minute hand.

$\omega = \dots\dots\dots \text{ rad s}^{-1}$ [2]

(c) During a time interval of 1400 s, the centre of gravity of the piece of modelling clay in Fig. 1.1 moves through a total distance of 0.44 m.

(i) Calculate the angle through which the minute hand moves in this time interval.

angle = $\dots\dots\dots \text{ rad}$ [1]

(ii) Determine distance L .

$L = \dots\dots\dots\text{m}$ [2]

(iii) Calculate the magnitude of the centripetal acceleration of the piece of modelling clay.

centripetal acceleration = $\dots\dots\dots\text{ms}^{-2}$ [2]

(d) Use your answer in (c)(iii) to explain why the variation with time of the magnitude of the force exerted by the minute hand on the piece of modelling clay is negligible as the minute hand undergoes one full revolution.

.....
.....
..... [2]

[Total: 10]

Answer:

Question	Answer	Marks
(a)	angle (subtended at centre of circle) when arc length = radius	B1
(b)	$\omega = 2\pi / T$	C1
	$= 2\pi / (1.0 \times 60 \times 60)$ $= 1.7 \times 10^{-3} \text{ rad s}^{-1}$	A1
(c)(i)	angle $= 1.7 \times 10^{-3} \times 1400$ $= 2.4 \text{ rad}$	A1
(c)(ii)	$L = \text{arc length} / \text{angle}$ $= 0.44 / 2.4$ or $L = 0.44 \times (3600 / 1400) / 2\pi$	C1
	$L = 0.18 \text{ m}$	A1
(c)(iii)	$a = r\omega^2$	C1
	$= 0.18 \times (1.745 \times 10^{-3})^2$ $= 5.5 \times 10^{-7} \text{ m s}^{-2}$	A1
(d)	centripetal acceleration is negligible compared with acceleration of free fall or numerical comparison establishing answer to (c)(iii) $\ll 9.81$	B1
	resultant force is negligible compared with weight (of modelling clay) (so variation is negligible) or force exerted by minute hand (approximately) equal (and opposite) to weight of modelling clay	B1

_____ compiled by examinent.com _____

4. 9702_w21_qp_41 Q: 1

(a) With reference to velocity and acceleration, describe uniform circular motion.

.....

 [2]

(b) Two cars are moving around a horizontal circular track. One car follows path X and the other follows path Y, as shown in Fig. 1.1.

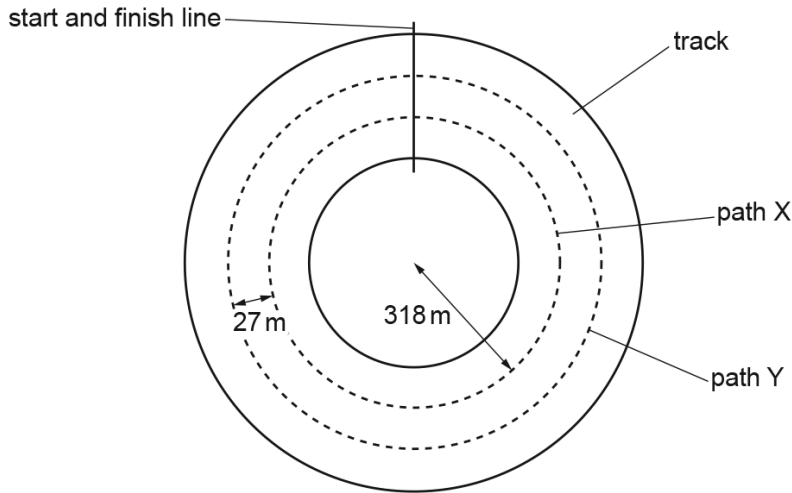

Fig. 1.1 (not to scale)

The radius of path X is 318 m. Path Y is parallel to, and 27 m outside, path X. Both cars have mass 790 kg. The maximum lateral (sideways) friction force F that the cars can experience without sliding is the same for both cars.

(i) The maximum speed at which the car on path X can move around the track without sliding is 94 m s^{-1} .

Calculate F .

$F = \dots\dots\dots \text{ N [2]}$

- (ii) Both cars move around the track. Each car has the maximum speed at which it can move without sliding.

Complete Table 1.1, by placing one tick in each row, to indicate how the quantities indicated for the car on path Y compare with the car on path X.

Table 1.1

	Y less than X	Y same as X	Y greater than X
centripetal acceleration			
maximum speed			
time taken for one lap of the track			

[3]

[Total: 7]

Answer:

	Answer	Marks
(a)	constant speed or constant magnitude of velocity	B1
	acceleration (always) perpendicular to velocity	B1
(b)(i)	$F = mv^2 / r$ or $v = r\omega$ and $F = mr\omega^2$	C1
	$F = 790 \times 94^2 / 318$ $= 22000 \text{ N}$	A1
(b)(ii)	centripetal acceleration: same	B1
	maximum speed: greater	B1
	time taken for one lap of the track: greater	B1

compiled by examinent.com

5. 9702_w21_qp_42 Q: 1

(a) State what is meant by *centripetal* acceleration.

.....

 [1]

(b) An unpowered toy car moves freely along a smooth track that is initially horizontal. The track contains a vertical circular loop around which the car travels, as shown in Fig. 1.1.

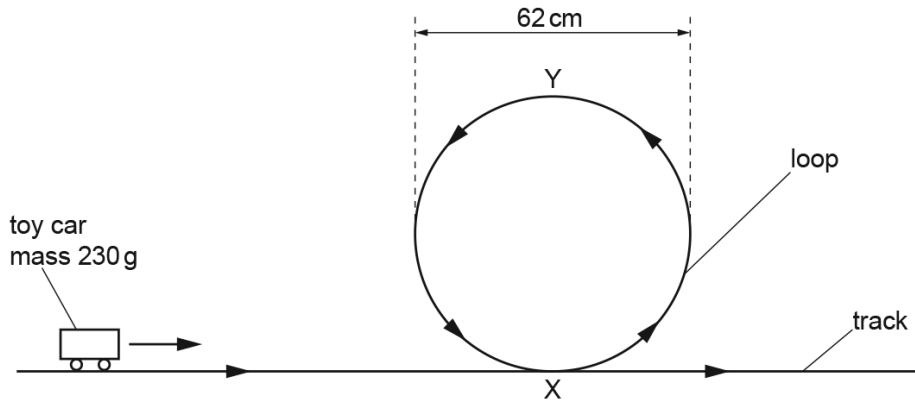

Fig. 1.1

The mass of the car is 230 g and the diameter of the loop is 62 cm. Assume that the resistive forces acting on the car are negligible.

(i) State what happens to the magnitude of the centripetal acceleration of the car as it moves around the loop from X to Y.

..... [1]

(ii) Explain, if the car remains in contact with the track, why the centripetal acceleration of the car at point Y must be greater than 9.8 m s^{-2} .

.....

 [2]

- (c) The initial speed at which the car in (b) moves along the track is 3.8 m s^{-1} .

Determine whether the car is in contact with the track at point Y. Show your working.

[3]

- (d) Suggest, with a reason but without calculation, whether your conclusion in (c) would be different for a car of mass 460g moving with the same initial speed.

.....

 [1]

[Total: 8]

Answer:

	Answer	Marks
(a)	acceleration perpendicular to velocity	B1
(b)(i)	decreases	B1
(b)(ii)	(acceleration of) 9.8 m s^{-2} is caused by weight of car or centripetal force must be greater than weight of car	B1
	(acceleration $> 9.8 \text{ m s}^{-2}$) requires contact <u>force</u> from track or (centripetal force $>$ weight) requires contact <u>force</u> from track	B1
(c)	$\frac{1}{2}mv_Y^2 = \frac{1}{2}mv_X^2 - mgh$	C1
	$a = v^2 / r$	C1
	$v_Y^2 = 3.8^2 - 2 \times 9.81 \times 0.62$ so $v_Y = 1.5 \text{ m s}^{-1}$	A1
	$a = 1.5^2 / 0.31 = 7.3 \text{ m s}^{-2}$ (which is less than 9.8 m s^{-2}) so no	
	or $v_Y = \sqrt{9.81 \times 0.31} = 1.74 \text{ m s}^{-1}$ so $v_X^2 = 1.74^2 + 2 \times 9.81 \times 0.62$ $v_X = 3.9 \text{ m s}^{-1}$ (which is greater than 3.8 m s^{-1}) so no	(A1)
(d)	acceleration is independent of mass so makes no difference or mass cancels in the equation so makes no difference	B1

compiled by examinent.com

Chapter 2

Gravitational fields

2.1 Gravitational force between point masses

6. 9702_s23_qp_42 Q: 1

(a) State Newton's law of gravitation.

.....

 [2]

(b) A satellite is in a circular orbit around a planet. The radius of the orbit is R and the period of the orbit is T . The planet is a uniform sphere.

Use Newton's law of gravitation to show that R and T are related by

$$4\pi^2 R^3 = GMT^2$$

where M is the mass of the planet and G is the gravitational constant.

[2]

(c) The Earth may be considered to be a uniform sphere of mass 5.98×10^{24} kg and radius 6.37×10^6 m.

A geostationary satellite is in orbit around the Earth.

Use the expression in (b) to determine the height of the satellite above the Earth's surface.

height = m [3]

Another satellite is in a circular orbit around the Earth with the same orbital radius and period as the satellite in (c).

(i) Calculate the angular speed of the satellite in this orbit. Give a unit with your answer.

angular speed = unit [2]

(ii) Despite having the same orbital period, the orbit of this satellite is not geostationary.

Suggest **two** ways in which the orbit of this satellite could be different from the orbit of the satellite in (c).

1

.....

2

.....

[2]

[Total: 11]

Answer:

Question	Answer	Marks
(a)	(gravitational) force is (directly) proportional to product of masses	B1
	force (between point masses) is inversely proportional to the square of their separation	B1
(b)	$G M m / R^2 = m R \omega^2$	M1
	$\omega = 2\pi / T$ and algebra leading to $4\pi^2 R^3 = G M T^2$	A1
	or	
	$G M m / R^2 = m v^2 / R$	(M1)
	$v = 2\pi R / T$ and algebra leading to $4\pi^2 R^3 = G M T^2$	(A1)
(c)	$4\pi^2 \times R^3 = 6.67 \times 10^{-11} \times 5.98 \times 10^{24} \times (24 \times 60 \times 60)^2$ $(R = 4.22 \times 10^7 \text{ m})$	C1
	$h = R - (6.37 \times 10^6)$	C1
	$h = (4.22 \times 10^7) - (6.37 \times 10^6)$ $= 3.6 \times 10^7 \text{ m}$	A1
(d)(i)	$\omega = 2\pi / T$	C1
	$= 2\pi / (24 \times 60 \times 60)$	A1
	$= 7.3 \times 10^{-5} \text{ rad s}^{-1}$	
(d)(ii)	orbit is from east to west	B1
	orbit is not equatorial / orbit is polar	B1

_____ compiled by examinent.com _____

7. 9702_m22_qp_42 Q: 1

(a) The point P in Fig. 1.1 represents a point mass.

On Fig. 1.1, draw lines to represent the gravitational field around P.



Fig. 1.1

[2]

(b) A moon is in circular orbit around a planet.

Explain why the path of the moon is circular.

.....

.....

.....

..... [2]

- (c) Many moons are in circular orbit about a planet.

The angular velocity of a moon is ω when the orbit of the moon has a radius r about the planet.

Fig. 1.2 shows the variation of r^3 with $1/\omega^2$ for these moons.

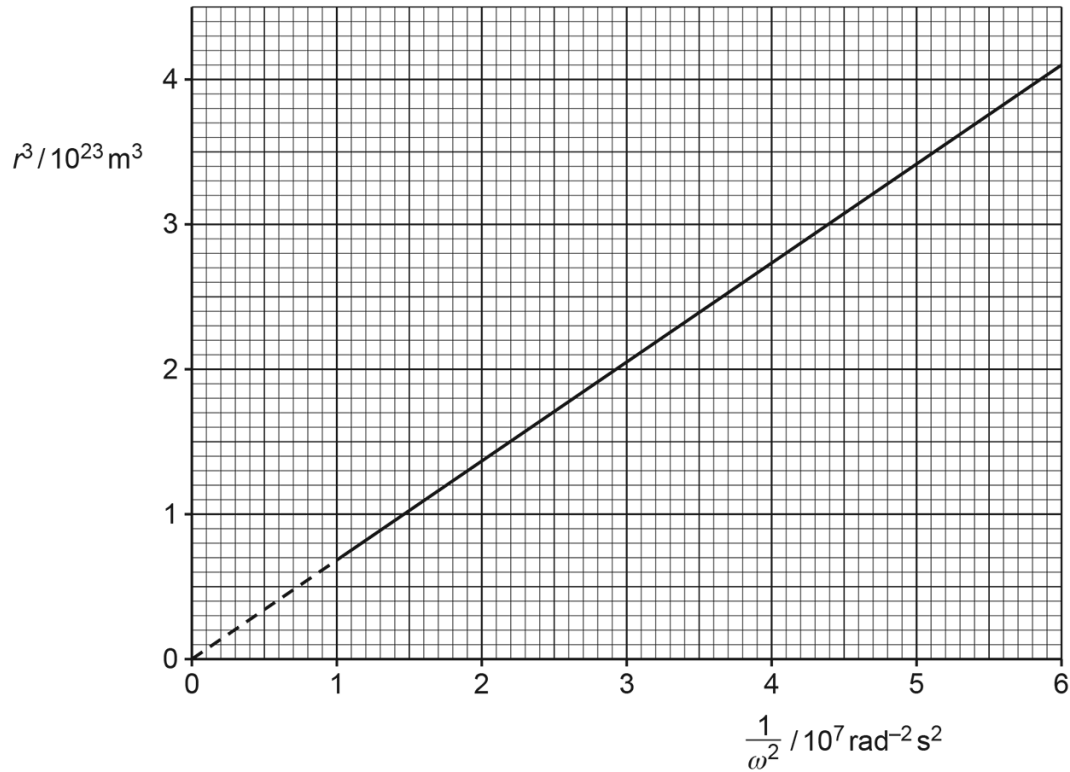

Fig. 1.2

- (i) Show that the mass M of the planet is given by the expression

$$M = \frac{\text{gradient}}{G}$$

where G is the gravitational constant.

[2]

- (ii) Use Fig. 1.2 and the expression in (c)(i) to show that the mass M of the planet is 1.0×10^{26} kg.

[1]

- (iii) Determine the speed of a moon in orbit around the planet with an orbital radius of 1.2×10^8 m.

speed = ms^{-1} [3]

[Total: 10]

Answer:

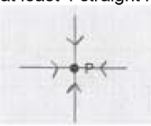
Question	Answer	Marks
(a)	at least 4 straight radial lines to P 	B1
	all arrows pointing along the lines towards P	B1
(b)	Any 2 from: gravitational force provides the centripetal force (centripetal or gravitational) force has constant magnitude (centripetal or gravitational) force is perpendicular to velocity (of moon) / direction of motion (of moon)	B2
(c)(i)	$\frac{GMm}{r^2} = m\omega^2 r$	M1
	$M = \frac{r^3 \omega^2}{G}$ and gradient = $r^3 \omega^2$ hence $M = \frac{\text{gradient}}{G}$ or $r^3 = GM \times 1/\omega^2$ so gradient = GM hence $M = \frac{\text{gradient}}{G}$	A1
(c)(ii)	$M = 4.1 \times 10^{23} / (6.0 \times 10^7 \times 6.67 \times 10^{-11}) = 1.0 \times 10^{26}$ kg	B1

Question	Answer	Marks
(c)(iii)	$\frac{GMm}{r^2} = \frac{mv^2}{r}$ $\frac{GM}{r} = v^2$	C1
	$v^2 = \frac{6.67 \times 10^{-11} \times 1.0 \times 10^{26}}{1.2 \times 10^8}$ $v^2 = 5.6 \times 10^7 \text{ m s}^{-1}$	C1
	$v = 7500 \text{ m s}^{-1}$	A1

compiled by examinent.com

8. 9702_w22_qp_41 Q: 1

- (a) State the equation for the gravitational force F between two point masses m_1 and m_2 that are separated by a distance r . State the meaning of any other symbols you use.

[2]

- (b) A satellite is in a circular orbit of radius R around a planet of mass M .

Show that the period T of the orbit is given by

$$T^2 = kR^3$$

where k is a constant that depends on the value of M . Explain your reasoning.

[3]

- (c) A satellite is in a circular orbit around the Earth with a period of 24 hours. The mass of the Earth is 6.0×10^{24} kg.

- (i) Calculate the radius of the orbit.

radius = m [2]

(ii) State the **two** other conditions that must be met for the orbit to be geostationary.

1

.....

2

.....

[2]

[Total: 9]

Answer:

Question	Answer	Marks
(a)	$F = (Gm_1m_2) / r^2$	M1
	where G is the gravitational constant	A1
(b)	gravitational force provides the centripetal force	B1
	$mR\omega^2 = GMm / R^2$ and $\omega = 2\pi / T$ or $mv^2 / R = GMm / R^2$ and $v = 2\pi R / T$ or $4\pi^2 mR / T^2 = GMm / R^2$	M1
	correct completion of algebra to get $T^2 = (4\pi^2 / GM) R^3$, with identification of $(4\pi^2 / GM)$ as k	A1
(c)(i)	$(24 \times 3600)^2 = (4\pi^2 \times R^3) / (6.67 \times 10^{-11} \times 6.0 \times 10^{24})$	C1
	$R = 4.2 \times 10^7$ m	A1
(c)(ii)	(orbit) must be above the Equator	B1
	(direction) must be from west to east	B1

compiled by examinent.com

9. 9702_w22_qp_42 Q: 1

(a) Define gravitational field.

.....
..... [1]

(b) A spherical planet can be considered as a point mass at its centre.

(i) On Fig. 1.1, draw gravitational field lines outside the planet to represent the gravitational field due to the planet.

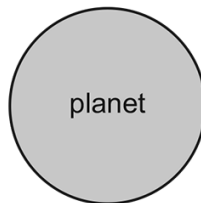

Fig. 1.1

[2]

(ii) A satellite is in a circular orbit around the planet.

Explain, with reference to your answer in (b)(i), why the path of the satellite is circular.

.....
.....
..... [2]

- (c) An object rests on the surface of the Earth at the Equator.
The radius of the Earth is 6.4×10^6 m.
- (i) Determine the centripetal acceleration of the object.

centripetal acceleration = ms^{-2} [3]

- (ii) Describe how the two forces acting on the object give rise to this centripetal acceleration.
You may draw a diagram if you wish.

.....
.....
..... [2]

[Total: 10]

Answer:

Question	Answer	Marks
(a)	force per unit mass	B1
(b)(i)	lines drawn are radial from the surface	B1
	arrows show pointing towards planet	B1
(b)(ii)	field lines show force (on satellite) is towards centre of planet or velocity of satellite is perpendicular to field lines	B1
	(gravitational) force perpendicular to velocity causes centripetal <u>acceleration</u>	B1
(c)(i)	$T = 24$ hours	C1
	$a = r\omega^2$ and $\omega = 2\pi / T$ or $a = v^2 / r$ and $v = 2\pi r / T$ or $a = 4\pi^2 r / T^2$	C1
	$a = (4\pi^2 \times 6.4 \times 10^6) / (24 \times 60 \times 60)^2$ $= 0.034 \text{ m s}^{-2}$	A1
(c)(ii)	identification of the two forces acting on the object as gravitational force and (normal) contact force	M1
	gravitational force and normal contact force are in opposite directions, and their resultant causes the (centripetal) acceleration	A1

_____ compiled by examinent.com _____

10. 9702_s20_qp_41 Q: 1

(a) State what is meant by a *gravitational force*.

.....
 [1]

(b) A binary star system consists of two stars S_1 and S_2 , each in a circular orbit.The orbit of each star in the system has a period of rotation T .

Observations of the binary star from Earth are represented in Fig. 1.1.

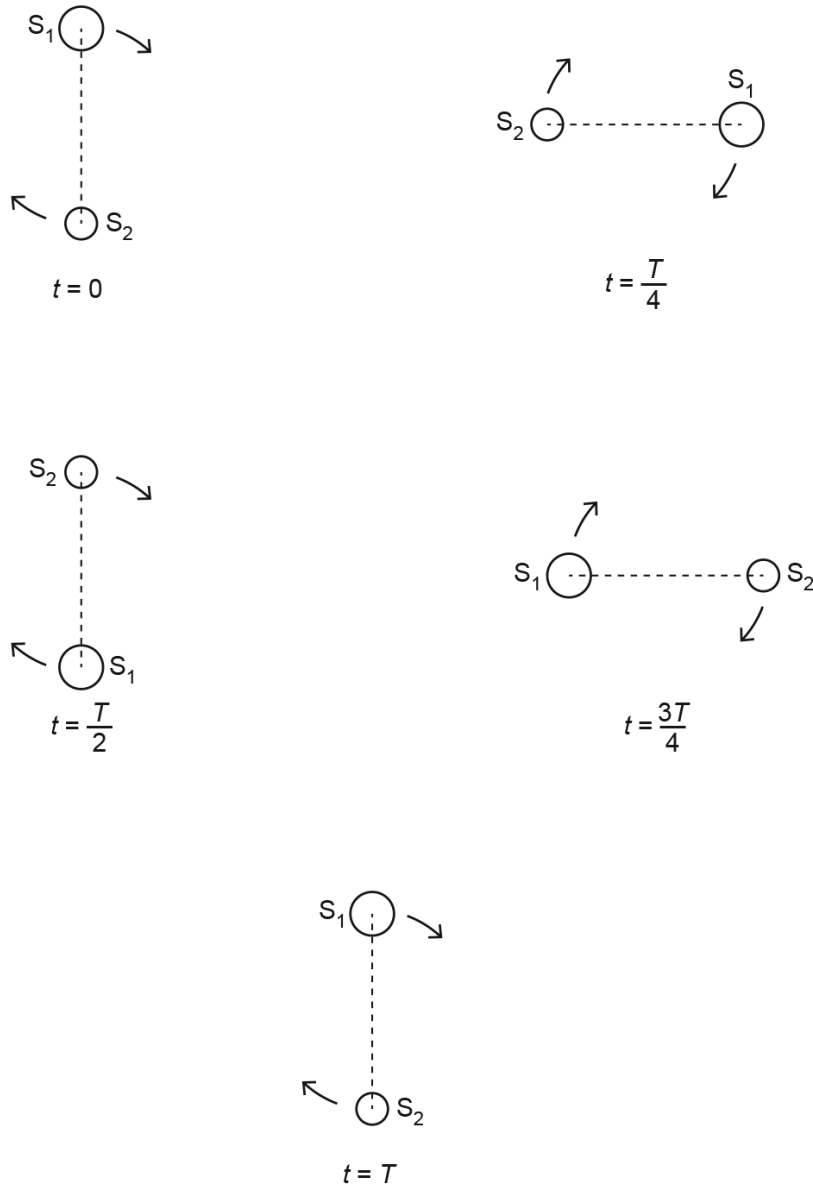

Fig. 1.1 (not to scale)

Observed from Earth, the angular separation of the centres of S_1 and S_2 is 1.2×10^{-5} rad. The distance of the binary star system from Earth is 1.5×10^{17} m.

Show that the separation d of the centres of S_1 and S_2 is 1.8×10^{12} m.

[1]

- (c) The stars S_1 and S_2 rotate with the same angular velocity ω about a point P, as illustrated in Fig. 1.2.

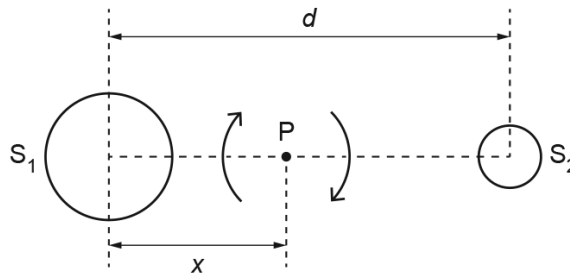

Fig. 1.2 (not to scale)

Point P is at a distance x from the centre of star S_1 . The period of rotation of the stars is 44.2 years.

- (i) Calculate the angular velocity ω .

$$\omega = \dots\dots\dots \text{rads}^{-1} \quad [2]$$

- (ii) By considering the forces acting on the two stars, show that the ratio of the masses of the stars is given by

$$\frac{\text{mass of } S_1}{\text{mass of } S_2} = \frac{d-x}{x}.$$

[2]

- (iii) The mass M_1 of star S_1 is given by the expression

$$GM_1 = d^2(d-x)\omega^2$$

where G is the gravitational constant.

The ratio in (ii) is found to be 1.5.

Use data from (b) and your answer in (c)(i) to determine the mass M_1 .

$$M_1 = \dots\dots\dots \text{ kg [3]}$$

[Total: 9]

Answer:

	Answer	Marks
(a)	force acting between two masses or force on mass due to another mass or force on mass in a gravitational field	B1
(b)	arc length = $r\theta$ $d = 1.5 \times 10^{17} \times 1.2 \times 10^{-5} = 1.8 \times 10^{12} \text{ m}$	A1
(c)(i)	$\omega = 2\pi / T$	C1
	$= 2\pi / (44.2 \times 365 \times 24 \times 3600)$ $= 4.5 \times 10^{-9} \text{ rad s}^{-1}$	A1
(c)(ii)	gravitational forces are equal or centripetal force about P is the same	C1
	$M_1 x \omega^2 = M_2 (d - x) \omega^2$ so $M_1 / M_2 = (d - x) / x$	A1
(c)(iii)	$x = 0.4d$	C1
	$6.67 \times 10^{-11} \times M_1 = (1.0 - 0.4) \times (1.8 \times 10^{12})^3 \times (4.5 \times 10^{-9})^2$	C1
	$M_1 = 1.1 \times 10^{30} \text{ kg}$	A1

_____ compiled by examinent.com _____

11. 9702_s19_qp_42 Q: 1

- (a) Two point masses are separated by a distance x in a vacuum.
State an expression for the force F between the two masses M and m .
State the name of any other symbol used.

.....

[1]

- (b) A small sphere S is attached to one end of a rod, as shown in Fig. 1.1.

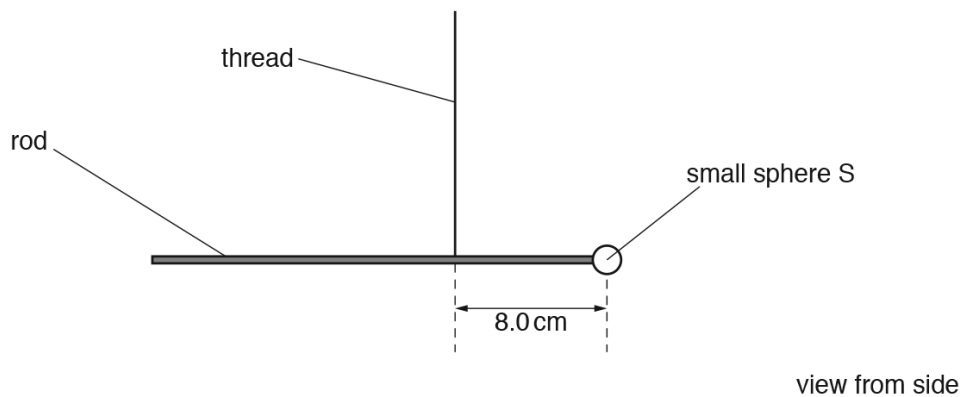

Fig. 1.1 (not to scale)

The rod hangs from a vertical thread and is horizontal.
The distance from the centre of sphere S to the thread is 8.0 cm.

A large sphere L is placed near to sphere S , as shown in Fig. 1.2.

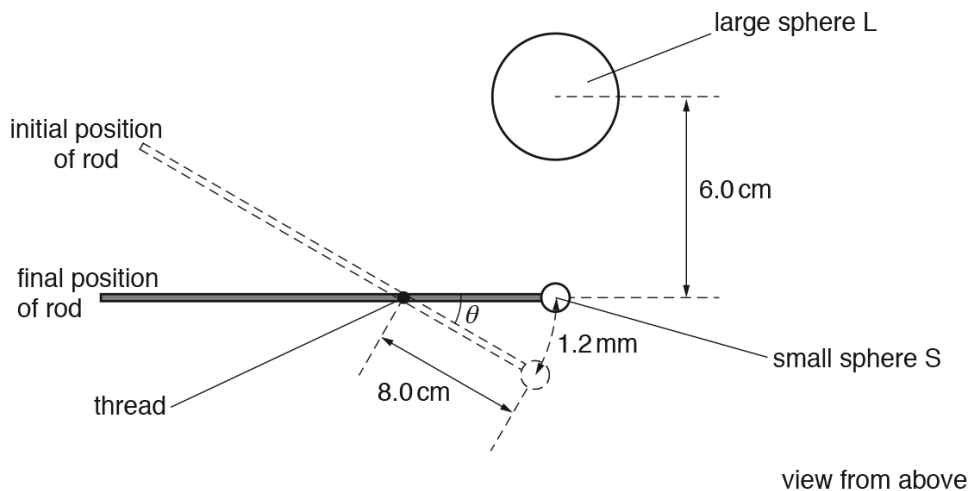

Fig. 1.2 (not to scale)

There is a force of attraction between spheres S and L, causing sphere S to move through a distance of 1.2 mm.
The line joining the centres of S and L is normal to the rod.

- (i) Show that the angle θ through which the rod rotates is 1.5×10^{-2} rad.

[1]

- (ii) The rotation of the rod causes the thread to twist.
The torque T (in Nm) required to twist the thread through an angle β (in rad) is given by

$$T = 9.3 \times 10^{-10} \times \beta.$$

Calculate the torque in the thread when sphere L is positioned as shown in Fig. 1.2.

torque = Nm [1]

- (c) The distance between the centres of spheres S and L is 6.0 cm.
The mass of sphere S is 7.5 g and the mass of sphere L is 1.3 kg.
- (i) By equating the torque in (b)(ii) to the moment about the thread produced by gravitational attraction between the spheres, calculate a value for the gravitational constant.

gravitational constant = $\text{Nm}^2\text{kg}^{-2}$ [3]

- (ii) Suggest why the total force between the spheres may not be equal to the force calculated using Newton's law of gravitation.

.....
[1]

[Total: 7]

Answer:

	Answer	Marks
(a)	$(F =) GMm / x^2$, where G is the (universal) gravitational constant	B1
(b)(i)	angle = $(1.2 \times 10^{-3}) / (8.0 \times 10^{-2}) = 1.5 \times 10^{-2}$ (rad)	B1
(b)(ii)	torque = $1.5 \times 10^{-2} \times 9.3 \times 10^{-10}$ = 1.4×10^{-11} N m	A1
(c)(i)	force $\times 8.0 \times 10^{-2} = 1.4 \times 10^{-11}$	C1
	$(G \times 1.3 \times 7.5 \times 10^{-3} \times 8.0 \times 10^{-2}) / (6.0 \times 10^{-2})^2 = 1.4 \times 10^{-11}$	C1
	$G = 6.4 \times 10^{-11}$ N m ² kg ⁻²	A1
(c)(ii)	Any one from: <ul style="list-style-type: none"> • law applies only to point masses/spheres are not point masses • radii of spheres not small compared with separation • spheres may not be uniform • the masses are not isolated • force between L and rod • spheres may be charged/may be electrostatic force (between spheres) 	B1

_____ compiled by examinent.com _____

12. 9702_s18_qp_41 Q: 1

(a) State Newton’s law of gravitation.

.....

[2]

(b) A distant star is orbited by several planets. Each planet has a circular orbit with a different radius.

(i) Each planet orbits at constant speed.
 Explain whether the planets are in equilibrium.

.....

[1]

(ii) The radius of the orbit of a planet is R and the orbital period is T .

Data for some of the planets are given in Fig. 1.1.

planet	R/m	T^2/s^2
c	9.6×10^{10}	2.5×10^{11}
e	4.0×10^{11}	1.8×10^{13}
g	2.1×10^{12}	2.6×10^{15}

Fig. 1.1

The relationship between R and T is given by the expression

$$R^3 = kT^2.$$

1. Show that the constant k is given by the expression

$$k = \frac{GM}{4\pi^2}$$

where G is the gravitational constant and M is the mass of the star.

[3]

2. Use data from Fig. 1.1 for the three planets and the expression for k to calculate the mass M of the star.

$M = \dots\dots\dots$ kg [3]

[Total: 9]

Answer:

	Answer	Marks
(a)	force proportional to product of masses and inversely proportional to square of separation	B1
	idea of force between point masses	B1
(b)(i)	velocity changes/direction of motion changes/there is an acceleration/there is a resultant force so not in equilibrium	B1
(b)(ii)1.	gravitational force equals/is centripetal force	C1
	$Gm/R^2 = mR\omega^2$ and $\omega = 2\pi/T$ or $Gm/R^2 = mv^2/R$ and $v = 2\pi r/T$ or $Gm/R^2 = mR(2\pi/T)^2$	M1
	convincing algebra leading to $k = GM/4\pi^2$	A1
1(b)(ii)2.	correct use of R^3/T^2 for one planet (c gives 3.54×10^{21} ; e and g both give 3.56×10^{21})	C1
	$3.5(5) \times 10^{21} = (6.67 \times 10^{-11} \times M) / 4\pi^2$ $M = 2.1 \times 10^{33} \text{ kg}$	A1
	two or three values of R^3/T^2 correctly calculated and used in a valid way to find a value for M based on more than one k	B1

_____ compiled by examinent.com _____

13. 9702_m16_qp_42 Q: 1

(a) State Newton's law of gravitation.

.....

 [2]

(b) A satellite of mass m has a circular orbit of radius r about a planet of mass M . It may be assumed that the planet and the satellite are uniform spheres that are isolated in space.Show that the linear speed v of the satellite is given by the expression

$$v = \sqrt{\frac{GM}{r}}$$

where G is the gravitational constant.
 Explain your working.

[2]

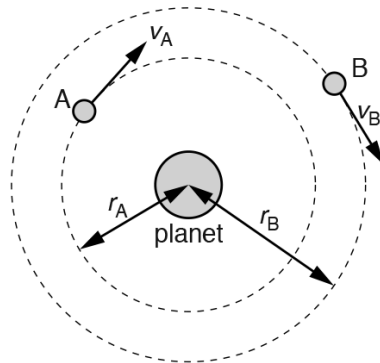
(c) Two moons A and B have circular orbits about a planet, as illustrated in Fig. 1.1.**Fig. 1.1** (not to scale)

Moon A has an orbital radius r_A of 1.3×10^8 m, linear speed v_A and orbital period T_A .
 Moon B has an orbital radius r_B of 2.2×10^{10} m, linear speed v_B and orbital period T_B .

(i) Determine the ratio

1. $\frac{V_A}{V_B}$,

ratio =[2]

2. $\frac{T_A}{T_B}$.

ratio =[3]

(ii) The planet spins about its own axis with angular speed $1.7 \times 10^{-4} \text{ rad s}^{-1}$.
Moon A is always above the same point on the planet's surface.

Determine the orbital period T_B of moon B.

$T_B = \dots\dots\dots \text{s}$ [2]

[Total: 11]

Answer:

- (a) force proportional to product of the (two) masses and inversely proportional to the square of their separation
either reference to point masses *or* separation \ll 'size' of masses M1
 A1 [2]
- (b) gravitational force provides/is the centripetal force B1
- $GMm/r^2 = mv^2/r$ *or* $GMm/r^2 = mr\omega^2$ and $v = r\omega$
 and algebra leading to $v = (GM/r)^{1/2}$ B1 [2]
- (c) (i) 1. $v_A/v_B = (r_B/r_A)^{1/2}$
 $= (2.2 \times 10^{10}/1.3 \times 10^8)^{1/2}$ C1
 $= 13$ (13.0) A1 [2]
2. $v = 2\pi r/T$ *or* $v \propto r/T$ *or* $vT/r = \text{constant}$ C1
 $T_A/T_B = (r_A/r_B) \times (v_B/v_A)$
 $= (1.3 \times 10^8/2.2 \times 10^{10}) \times (1/13)$ C1
 $= 4.5$ (4.54) $\times 10^{-4}$ A1
- or*
- $T^2 = 4\pi^2 r^3/GM$ *or* $T^2 \propto r^3$ *or* $T^2/r^3 = \text{constant}$ (C1)
 $T_A/T_B = (r_A^3/r_B^3)^{1/2}$
 $= [(1.3 \times 10^8)^3/(2.2 \times 10^{10})^3]^{1/2}$ (C1)
 $= 4.5$ (4.54) $\times 10^{-4}$ (A1) [3]
- (ii) $T = 2\pi/1.7 \times 10^{-4}$
 $= 3.70 \times 10^4 \text{ s}$ C1
 $T_B = 3.70 \times 10^4/4.54 \times 10^{-4}$
 $= 8.1 \times 10^7 \text{ s}$ A1 [2]
 If identifies T_A as T_B then 0/2

_____ compiled by examinent.com _____

14. 9702_w16_qp_41 Q: 1

A satellite is in a circular orbit of radius r about the Earth of mass M , as illustrated in Fig. 1.1.

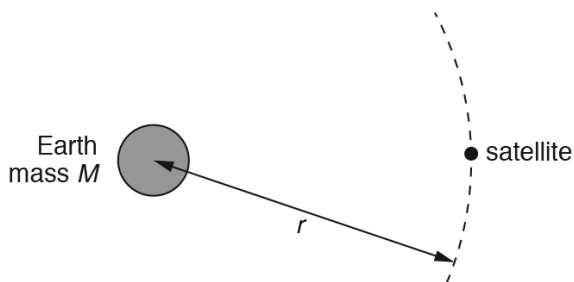

Fig. 1.1

The mass of the Earth may be assumed to be concentrated at its centre.

(a) Show that the period T of the orbit of the satellite is given by the expression

$$T^2 = \frac{4\pi^2 r^3}{GM}$$

where G is the gravitational constant. Explain your working.

[3]

(b) (i) A satellite in geostationary orbit appears to remain above the same point on the Earth and has a period of 24 hours.
State two other features of a *geostationary* orbit.

1.
.....
2.
.....

[2]

- (ii) The mass M of the Earth is 6.0×10^{24} kg.
Use the expression in (a) to determine the radius of a geostationary orbit.

radius = m [2]

- (c) A global positioning system (GPS) satellite orbits the Earth at a height of 2.0×10^4 km above the Earth's surface.
The radius of the Earth is 6.4×10^3 km.

Use your answer in (b)(ii) and the expression

$$T^2 \propto r^3$$

to calculate, in hours, the period of the orbit of this satellite.

period = hours [2]

[Total: 9]

Answer:

- (a) gravitational force provides/is the centripetal force B1
- $$GMm/r^2 = mv^2/r \quad \text{or} \quad GMm/r^2 = mr\omega^2$$
- $$\text{and } v = 2\pi r/T \quad \text{or} \quad \omega = 2\pi/T \quad \text{M1}$$
- with algebra to $T^2 = 4\pi^2 r^3 / GM$ A1 [3]
- or
- acceleration due to gravity is the centripetal acceleration (B1)
- $$GM/r^2 = v^2/r \quad \text{or} \quad GM/r^2 = r\omega^2$$
- $$\text{and } v = 2\pi r/T \quad \text{or} \quad \omega = 2\pi/T \quad \text{(M1)}$$
- with algebra to $T^2 = 4\pi^2 r^3 / GM$ (A1)
- (b) (i) equatorial orbit/orbits (directly) above the equator B1
- from west to east B1 [2]
- (ii) $(24 \times 3600)^2 = 4\pi^2 r^3 / (6.67 \times 10^{-11} \times 6.0 \times 10^{24})$ C1
- $$r^3 = 7.57 \times 10^{22}$$
- $$r = 4.2 \times 10^7 \text{ m} \quad \text{A1 [2]}$$
- (c) $(T/24)^2 = \{(2.64 \times 10^7) / (4.23 \times 10^7)\}^3$ B1
- $$= 0.243$$
- $T = 12 \text{ hours}$ A1 [2]
- or
- $$k (= T^2 / r^3) = 24^2 / (4.23 \times 10^7)^3 \quad \text{(B1)}$$
- $$= 7.61 \times 10^{-21}$$
- $$T^2 (= kr^3) = 7.61 \times 10^{-21} \times (2.64 \times 10^7)^3$$
- $$= 140$$
- $T = 12 \text{ hours}$ (A1)

_____ compiled by examinent.com _____

2.2 Gravitational field of a point mass

To access the full eBook and explore more content, visit:

www.examinent.com